

iQ-FLiP

High Speed Low Cost Scale

More Speed for Less



*Interface with
vertical bagger
or container indexing
conveyor*

- ◆ More Speed:
Up to 80 fills
per minute
- ◆ Low Cost
Compared to existing
multiple lane scales
or combination scales
- ◆ More Production with
Less Maintenance
 - Only 1 weigh hopper
 - Quick Changeover
 - Minimal contact
surfaces to clean
- ◆ Less Space
fits in a 4' cube

Available in 3 Models:

1 oz. to 2 lbs.

2 lbs. to 5 lbs.

5 lbs. to 30 lbs.



800-571-0249

www.weighright.com

iQ-FLiP

Fully Automate with Bagger
or Conveyor

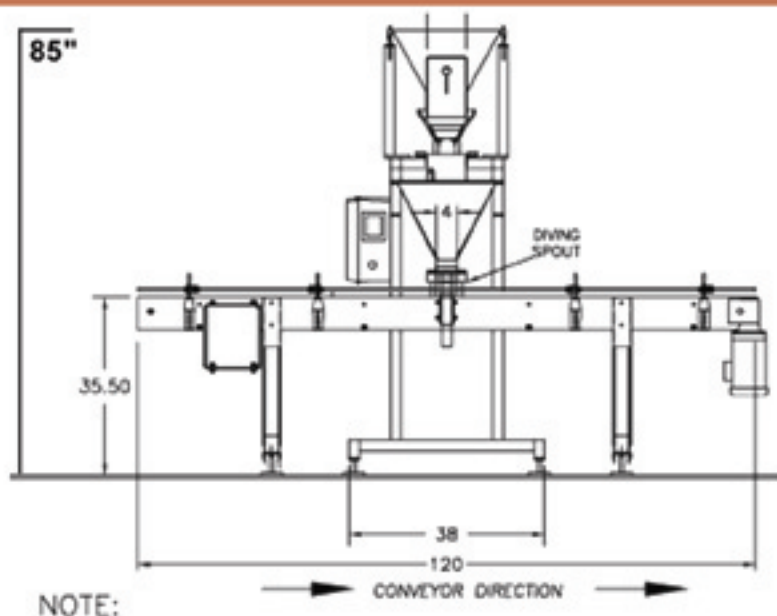

HOW IT WORKS:

The iQ-FLiP vibrates a continuous stream of product into a two-compartment high speed oscillating weigh bucket that quickly flips from one compartment to the next once the target weight has been met in the first.

iQ-FLiP with Indexing Conveyor:

The iQ-FLiP is ideal to fill nutmeats, small whole vegetables, coffee, seeds, granules, pellets, and small candies, into cans, jars, trays or tubs.

The iQ-Flip is available in three models: 1 oz. - 2 lbs., 2 lbs. - 5 lbs. and 5 lbs. - 30 lbs.

iQ-FLiP with Bagger:

The iQ-FLiP can be supported on a split support frame over the transition funnel of your bagger or mounted to the top plate on most vertical baggers. The short stack-up height is minimal compared to multiple lane linear scales and combination scales yet offering high speed filling.



Top view of coffee beans streaming into the flip style weigh bucket

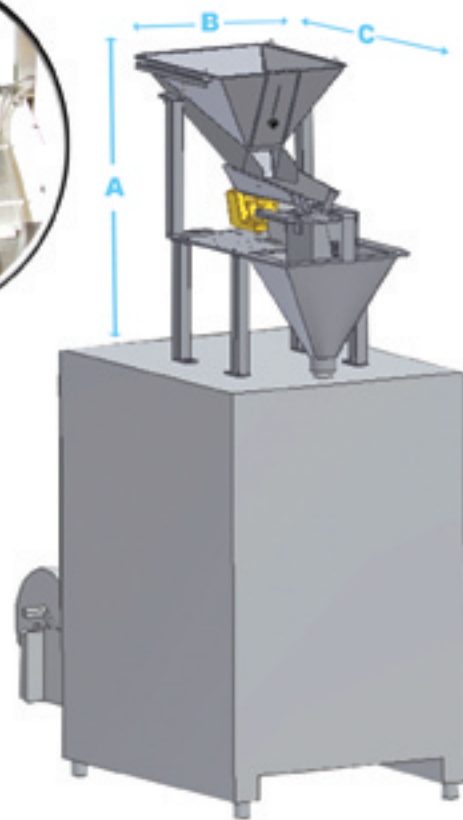

WEIGHTS AND RATES*

1 - 4 oz.	70-80 fills per minute
4 - 16 oz.	60 fills per minute
1 - 2 lbs.	40 fills per minute
2.5 - 3 lbs.	30 fills per minute
3.5 - 5 lbs.	20 fills per minute (may require double dump)

*Above rates are estimated and final guarantees subject to product samples and testing. Accuracy is subject to product piece size, density and consistent head pressure.



WEIGH RIGHT
Automatic Scale Co.

612-A Mills Rd. Joliet, IL 60433
Ph: 815-726-4626 Fax: 815-726-7638
800-571-0249 www.weighright.com

SPECIFICATIONS: Height (A) Width (B) Depth (C)
iQ-FLiP over bagger: 44 inches 24 inches 45 inches

Printed in the USA